



General

- Chip size from 0402 to 2512
- Resistance value from 10mΩ to 1000mΩ
- Compatible with Reflow and Wave Soldering processes
- Lead free, ROHS compliant for global
- Applications and halogen free

Application

- Switching model power supply
- Battery pack
- Notebook, personal computer
- Test Instrument
- Power Amplifier

Electrical Specifications

Type	Power Rating at 70°C (W)	Resistance Range (mΩ)	TCR (ppm/°C)	Resistance Tolerance	Operation Temp. Range
0402	1/16	100≤R<200	±700	±1%(F) ±2%(G) ±3%(H) ±5%(J)	-55°C~+155°C
		200≤R<499	±500		
		500≤R≤1000	±400		
0603	1/10	20≤R<33	±1500		
		33≤R<68	±1000		
		68≤R<100	±800		
		100≤R<200	±700		
		200≤R<500	±500		
		500≤R≤1000	±400		
0805	1/8	10≤R<20	±1500		
1206	1/4	20≤R<50	±1000		
1210	1/3	50≤R<100	±800		
2010	3/4	100≤R<200	±700		
2512	1	200≤R<500	±500		
		500≤R≤1000	±400		

Part Number Information

SKC 12 G D E R010 I

【1】 【2】 【3】 【4】 【5】 【6】 【7】

- 【1】 Series Name: SART Thick Film Low Resistance Type
- 【2】 Chip size: 04: 0402 06: 0603 08:0805 12:1206 13:1210 20:2010 25:2512
- 【3】 Material Code: G:Ag Alloy
- 【4】 Power Code: H:1/16W G:1/10W F:1/8W D:1/4W K:1/3W C:3/4W 1:1W
- 【5】 Resistance Tolerance: F:±1% G:±2% H:±3% J:±5%
- 【6】 Resistance Code: R010=10mΩ 6M50=6.5mΩ
- 【7】 Packaging Code: T:Tape& Reel B:Bulk Pack

Dimensions

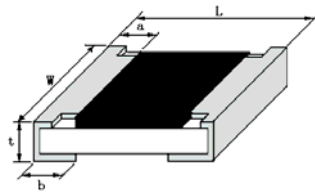

Type	L(mm)	W(mm)	T(mm)	A(mm)	B(mm)
0402	1.00±0.10	0.50±0.10	0.30±0.10	0.20±0.10	0.25±0.10
0603	1.60±0.15	0.80±0.15	0.40±0.10	0.30±0.20	0.30±0.20
0805	2.00±0.20	1.25±0.15	0.50±0.10	0.30±0.20	0.40±0.20
1206	3.20±0.20	1.60±0.15	0.55±0.10	0.50±0.20	0.50±0.20
1210	3.20±0.20	2.50±0.20	0.55±0.10	0.50±0.20	0.50±0.20
2010	5.00±0.20	2.50±0.20	0.55±0.10	0.60±0.20	0.60±0.20
2512	6.40±0.20	3.20±0.20	0.55±0.10	0.60±0.20	0.60±0.20

Recommended Land Patterns

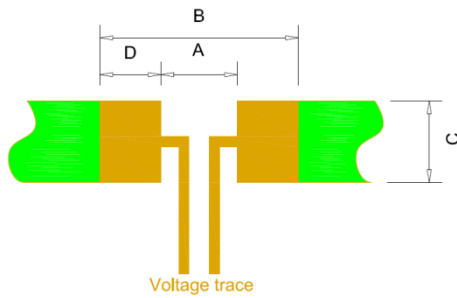

Type	A(mm)	B(mm)	C(mm)	D(mm)
0402	0.45	1.90	0.60	1.45
0603	0.80	5.80	0.95	2.50
0805	1.05	7.55	1.40	3.25
1206	1.90	10.90	1.75	4.50
1210	2.00	11.20	2.70	4.60
2010	3.50	16.50	2.70	6.50
2512	4.80	20.40	3.40	7.80

Materials

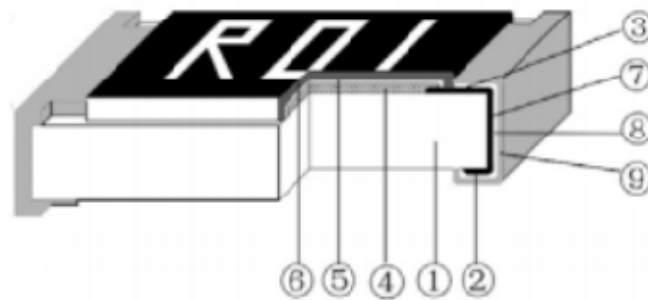

No.	Materials	No.	Materials
1	Ceramic Substrate	6	Marking
2	Bottom Electrode	7	Edge Electrode
3	Top Electrode	8	Barrier Layer
4	Resistor Layer	9	External Electrode
5	Overcoat	10	/

Power Derating Curve

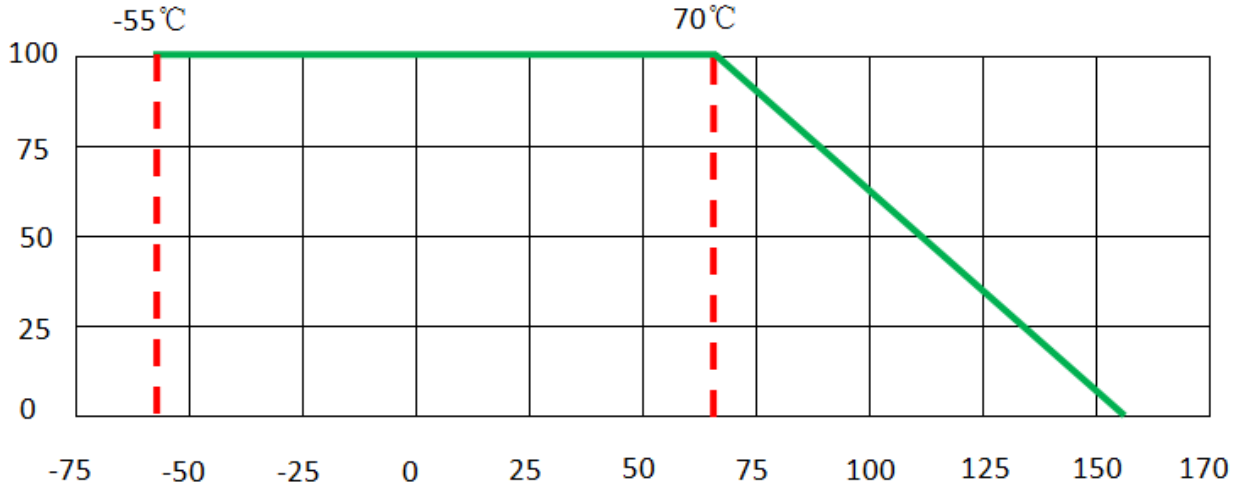

Recommended Solder Curve

1. Infrared Reflow

Temperature: 260°C

Time: 5sec Max.

Recommend Reflow profile:

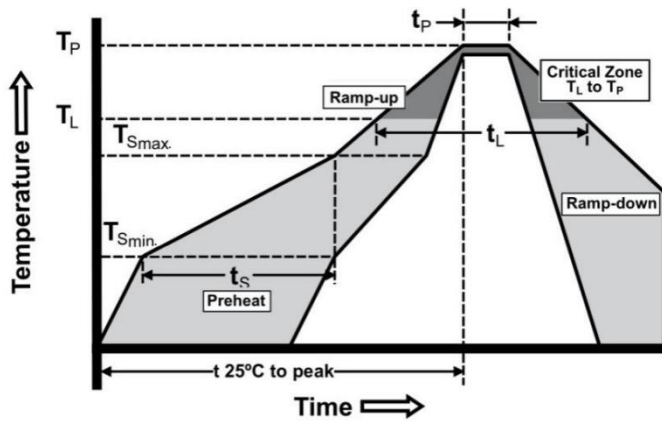

Profile Feature	Pb-Free Assembly
Average Ramp-Up Rate (T_{Smax} to T_p)	3°C/sec Max.
Preheat	
Temperature Min(T_{Smin})	150°C
Temperature Max(T_{Smax})	200°C
Time(T_{Smin} to T_{Smax})	60sec~120sec
Peak Temperature(T_p)	260°C
Time within 5°C of actual Peak Temperature(T_p)	5sec
Melting tin time(T_L)	20sec~30sec
Ramp-Down Rate	6°C/sec Max.
Time 25°C to Peak Temperature	8min Max.

2. Wave soldering

Reservoir Temperature: 260°C

Time in Reservoir: 10sec Max.

3. Hand Soldering

Temperature: 350°C

Time: 5sec Max.

Product Characteristics

Item	Test Condition/ Methods	Performance	Standard
Short Time Overload	2.5X rated power for 5sec	$ \Delta R \leq \pm 1\%$	IEC60115-1 4.13
Temperature Coefficient of Resistance (T.C.R.)	$TCR = \frac{(R - R_0)}{R_0} \frac{(T_2 - T_1)}{T_1} \times 10^6$ Test temperature: 25°C~125°C	Refer to SART Spec	IEC60115-1 4.8
Load Life	70°C ± 2°C, 1000 hours, at rated power 1.5 hours "ON", 0.5 hours "OFF"	$ \Delta R \leq \pm 1\%$	IEC60115-1 4.25
Bias Humidity	40°C ± 2°C, (93% ± 3%)RH, 1000 hours, at rated power 1.5 hours "ON", 0.5 hours "OFF"	$ \Delta R \leq \pm 1\%$	IEC60115-1 4.24
Thermal Shock	-55°C(30min)/+155°C(30min), 300 cycles	$ \Delta R \leq \pm 1\%$	IEC60115-1 4.19
Solder ability	245°C ± 5°C, 3.0sec ± 0.3sec	95%coverage Min.	IEC60115-1 4.17
Resistance to Soldering Heat	270°C ± 5°C, 10sec ± 1sec	$ \Delta R \leq \pm 1\%$	IEC60115-1 4.18
High temperature Exposure	155°C ± 2°C, 1000 hours	$ \Delta R \leq \pm 1\%$	IEC60115-1 4.23
Bending Test	Epoxy thickness 1.6mm, fulcrums distance 90mm, bending width 5mm(0402\0603\0805), bending width 4mm(1206\1210), bending width 2mm(2010\2512)	$ \Delta R \leq \pm 1\%$	IEC60115-1 4.33
Insulation Resistance	(100V±15V) DC	1000MΩ Min.	IEC60115-1 4.6
Operation at low temperature	-55°C ± 5°C, 1hour without load, rated voltage or limiting element voltage whichever is lower for 45 min, 15min without load	$ \Delta R \leq \pm 1\%$	IEC60115-1 4.25.3
Voltage proof	Apply max. overload voltage of AC RMS at a rate of approximately 100V/sec between substrate and terminations for 60sec ± 5sec	No breakdown or flash-over	IEC60115-1 4.7
Component solvent resistance	Iso-propyl alcohol (IPA) 23°C ± 5°C, 10hour	$ \Delta R \leq \pm 1\%$	IEC60115-1 4.29
Shear test	Applying force: 0603: 5N; 0805: 9N; 1206, 1210: 25N; 2010, 2512: 45N Duration: 10sec ± 1sec	No mechanical damage	IEC60115-1 4.32

Packaging

1. Paper Tape Dimensions

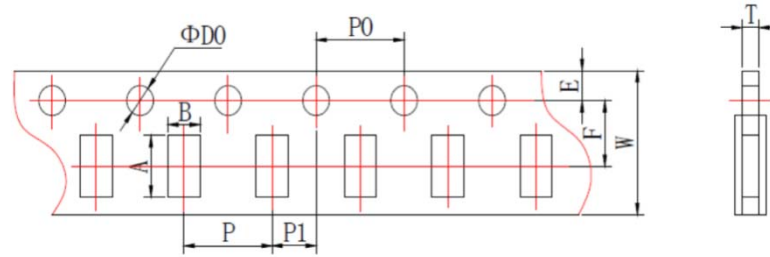

Type	A(mm)	B(mm)	W(mm)	F(mm)	E(mm)
0402	1.20±0.10	0.70±0.10	8.00±0.20	3.50±0.05	1.75±0.10
0603	1.85±0.10	1.10±0.10	8.00±0.20	3.50±0.05	1.75±0.10
0805	2.35±0.10	1.65±0.10	8.00±0.20	3.50±0.05	1.75±0.10
1206	3.50±0.20	1.90±0.20	8.00±0.20	3.50±0.05	1.75±0.10
1210	3.50±0.20	2.80±0.20	8.00±0.20	3.50±0.05	1.75±0.10
Type	P (mm)	P0(mm)	P1(mm)	D0(mm)	T(mm)
0402	2.00±0.05	4.00±0.10	2.00±0.05	1.50±0.10	0.42±0.05
0603	4.00±0.10	4.00±0.10	2.00±0.05	1.50±0.10	0.60±0.10
0805	4.00±0.10	4.00±0.10	2.00±0.05	1.50±0.10	0.75±0.10
1206	4.00±0.10	4.00±0.10	2.00±0.05	1.50±0.10	0.75±0.10
1210	4.00±0.10	4.00±0.10	2.00±0.05	1.50±0.10	0.75±0.10

2. Embossed Tape Dimensions

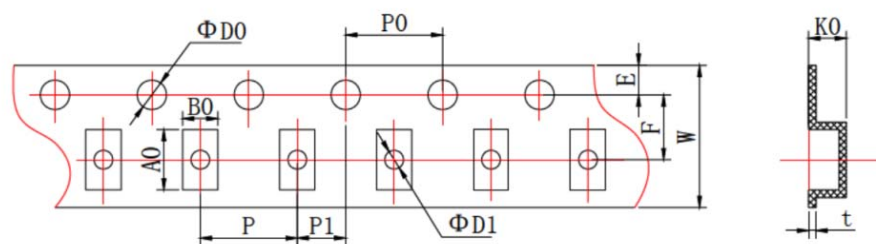

Type	A0(mm)	B0(mm)	W(mm)	F(mm)	E(mm)	t(mm)
2010	5.50±0.15	2.82±0.15	12.00±0.10	5.50±0.10	1.75±0.10	0.25±0.05
2512	6.78±0.15	3.45±0.15	12.00±0.10	5.50±0.10	1.75±0.10	0.25±0.05
Type	P(mm)	P0(mm)	P1(mm)	D0(mm)	D1(mm)	K0(mm)
2010	4.00±0.10	4.00±0.10	2.00±0.05	1.50 ^{+0.10} ₀	1.50±0.10	0.84±0.05
2512	4.00±0.10	4.00±0.10	2.00±0.05	1.50 ^{+0.10} ₀	1.50±0.10	0.81±0.10

3. Reel Dimensions

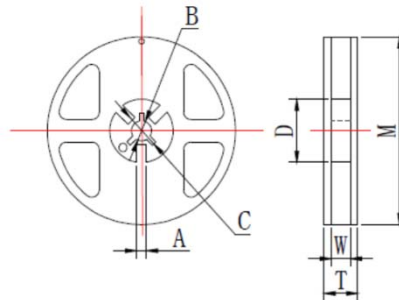

Type	M(mm)	W(mm)	T(mm)	A(mm)	B(mm)	C(mm)	D(mm)
0402 0603 0805 1206 1210	178.00±2.00	9.5±1.00	12.50±1.50	2.00±0.50	13.00±0.50	21.00±0.50	58.00±0.20
2010 2512	178.00±2.00	13.00±0.50	15.50±1.50	2.00±0.50	13.00±0.50	21.00±0.50	57.00±2.00

4. Quantity of Package

Type	0402	0603	0805	1206	1210	2010	2512
Quantity (pcs)	10000	5000				4000	

5. Peeling Test

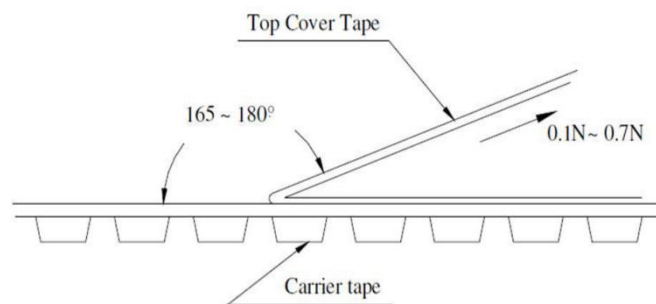

Storage

- The ambient temperature shall be between 5°C~30°C.
- The relative humidity recommended for storage is between 25%RH~60%RH.
- Sealed plastic bags with desiccant shall be used to reduce the oxidation of the termination and shall only be opened prior to use.
- The products shall not be stored in areas where harmful gases containing sulfur or chlorine are present.