

REV.	EGN.NO.	MODIFY CONTENT	DATE
A		NEW	2011/10/31

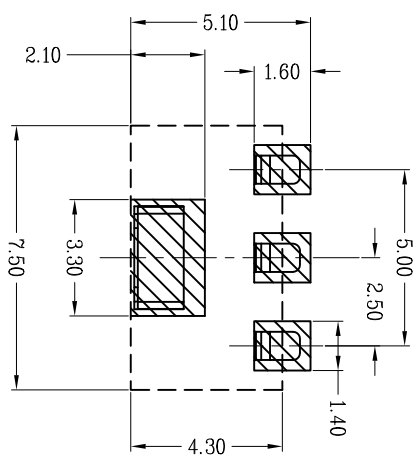

RECOMMENDED PCB LAYOUT
TOLERANCE: ±0.05

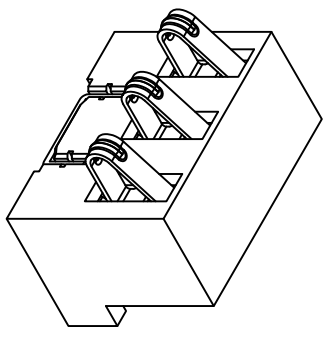
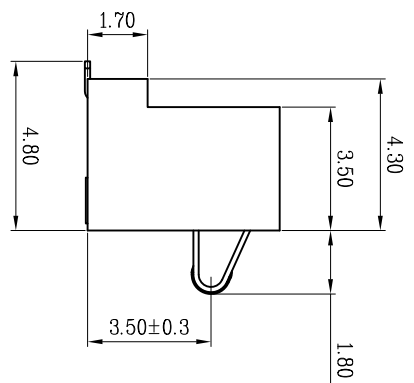
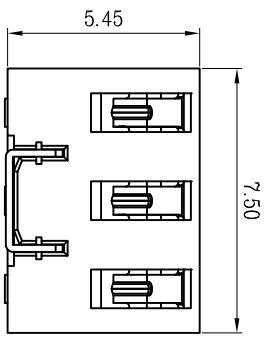
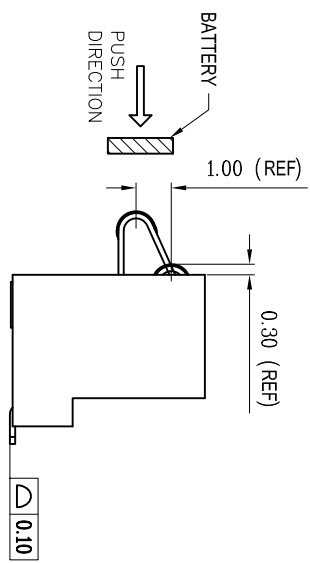
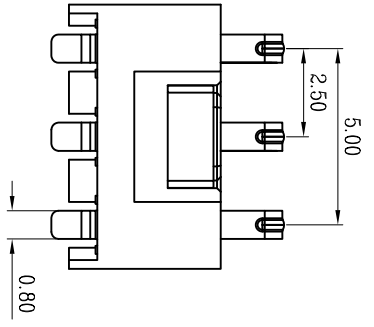

- NOTES:
- ELECTRICAL PERFORMANCES:
 - RATING CURRENT: 2A
 - RATING VOLTAGE: 100VAC
 - CONTACT RESISTANCE: 50 Ωm
 - INSULATION RESISTANCE: 1000 ΩM
 - DIELECTRIC WITHSTANDING VOLTAGE: 500VAC FOR 1 MINUTE
 - MECHANICAL PERFORMANCE:
 - DURABILITY: 5000TIMES
 - NORMAL FORCE AT WORKING POSITION: 80gf Min.
 - OPERATION TEMPERATURE: -40° C~+85° C.

ITEM	DESCRIPTION	QUANTITY	MATERIAL	FINISH	REMARK
③	PAD	1	STAINLESS STEEL	NI PLATING OVER ALL TIN PLATING OVER ALL	
②	CONTACT	3	COPPER ALLOY	AU PLATING OVER TIN PLATING OVER TIN AT CONTACT AREA TIN AT SOLDER AREA	
①	HOUSING	1	THERMOPLASTIC UL94V-0 COLOR:BLACK		

GENERAL TOLERANCE	DWG NO.	JYSA0405-04	APPD:	WMD	Scale	1:1
X.±0.45	X.±5°	Title	BATTERY 3PIN 2.50PINCH 5.4H A&K	CHKD:	UNIT	mm
X.±0.35	X.±2°	Part NO.	JYS-BY540-062	DR:	Date	2012/02/29
XX±0.25	.XX±1°					
.XXX±0.15	.xxx±0.5°					
SHEET	1/1					

JIS 杰宇森 电子有限公司
JIE YU SEN ELECTRONIC CO., LTD.