

REV.	ECN.NO.	MODIFY.CONTENT	DATE
A		NEW	2016/10/31

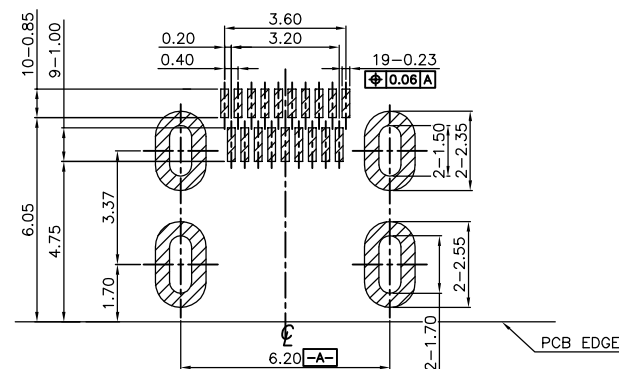

RECOMMENDED PCB LAYOUT(TOP VIEW)
(TOLERANCE: ±0.05mm)

PIN	Signal Assignment
1	Hot Plug Detect
2	Utility
3	TMDS Data2+
4	TMDS Data2 Shield
5	TMDS Data2-
6	TMDS Data1+
7	TMDS Data1 Shield
8	TMDS Data1-
9	TMDS Data0+
10	TMDS Data0 Shield
11	TMDS Data0-
12	TMDS Clock+
13	TMDS Clock Shield
14	TMDS Clock-
15	CEC
16	DDC/CEC Ground
17	SCL
18	SDA
19	+5V Power

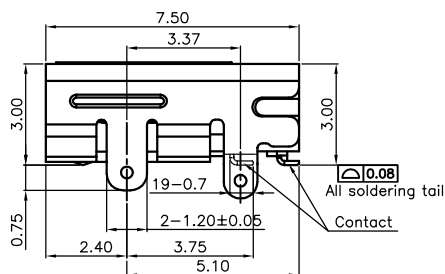
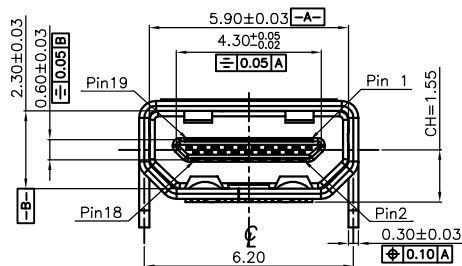
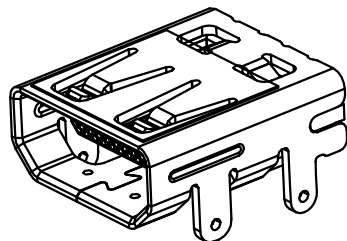
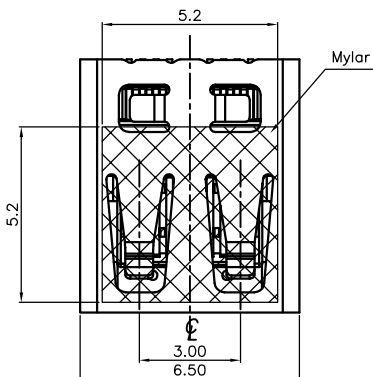
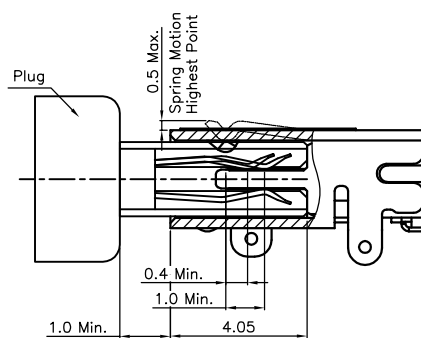
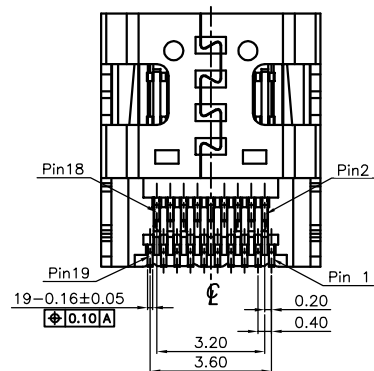

Receptacle and Plug Mated Condition

Notes:

- Materials
 - Housing: LCP+30% G/F, Black, UL94 V-0;
 - Contact: Phosphor Copper (C5191), Gold Plating at mating area, Matte Tin or Au Plating at solder tail, all over Nickel;
 - Shell: Phosphor Copper (C5191);
- Ratings
 - Current Rating: 0.3A ;
 - Operating Temperature: -40°C ~ 85°C;
- Electrical Requirement:
 - LLCR: Excluding Conductor Resistance 10mΩ Max.(Target design value), Contact: 30mΩ Max. changed (Final), Shell: 50mΩ Max. Changed (Final);
 - Dielectric Withstanding Voltage: 150V AC (RMS) for 1 minute (Mated), 250V AC (RMS) for 1 minute (Unmated);
 - Insulation Resistance: 10MΩ Min. @ 150V DC (Mated), 100MΩ Min. @ 500V DC (Unmated);
- Mechanical Performance:
 - Insertion force: 44.1N (4.5Kgf) Max.;
 - Withdrawal force: 4.9~25N (0.5~2.5Kgf);
 - Durability life: 5,000 Cycles;
- IR Reflow: the peak temperature on board shall be maintained for 10 seconds at 260±5°C.

GENERAL TOLERANCE		DWG NO.	JYSA0909-001	APPD:	WIND	Scale	1:1
X.±0.45	x.±5°	Title	HDMI D TYPE板上型CH=1.55 双排SMT 外壳四脚插件	CHKD:		UNIT	mm
.X±0.35	.x.±2°			DR:			
.XX±0.25	.xx.±1°	Part NO.	JYS-HD295-001	Date	2016/10/31		
.XXX±0.15	.xxx.±0.5°						
SHEET	1/2			 JYSCONN Shenzhen JYSCONN Electronics Co., LTD.			

REV.	ECN.NO.	MODIFY.CONTENT	DATE
A		NEW	2016/10/31

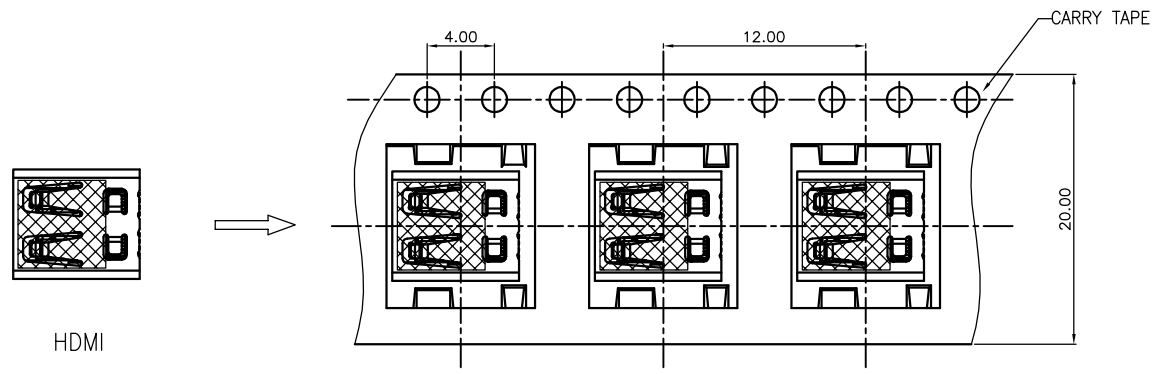
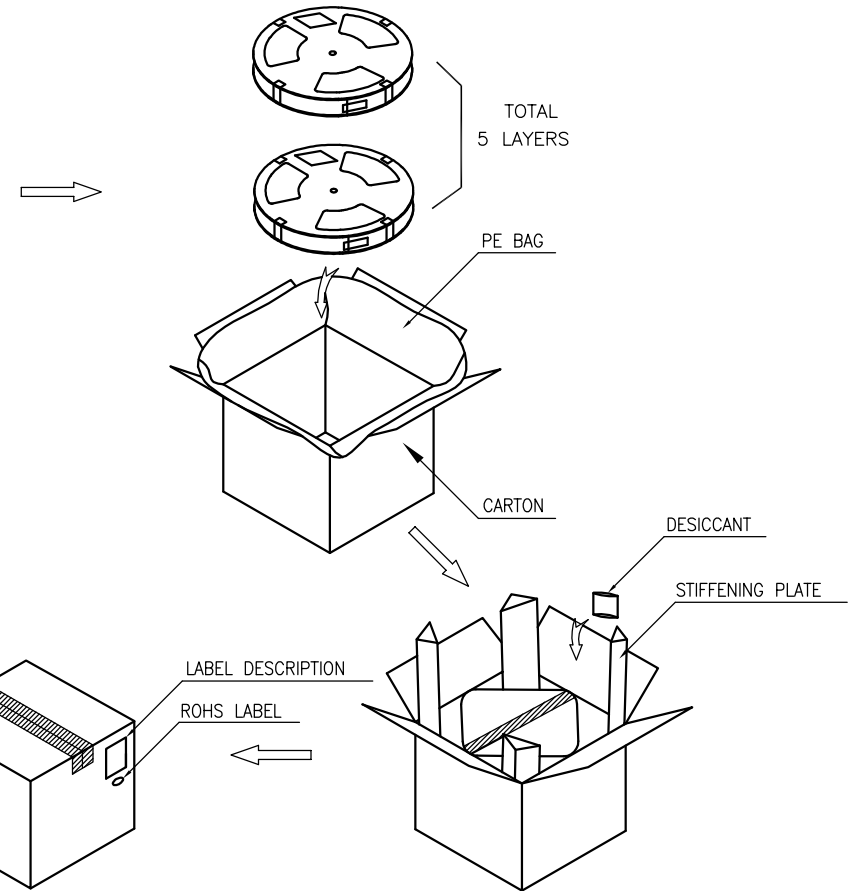
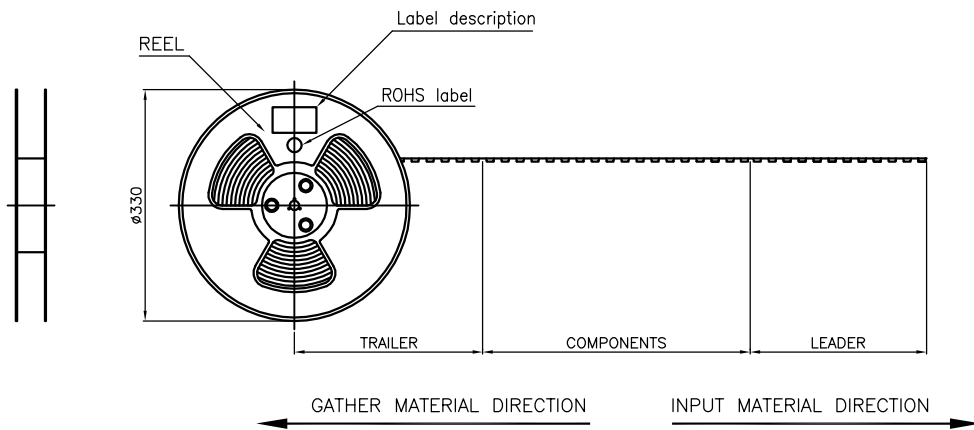

- Notes:
1. The start and end of each reel, based on the actual quantity, reserved 10--15pcs space;
 2. Peel off force of top tape: 10g~130g, peel deg.:165°~175°; peel speed: 250~300mm/min;
 3. Carton size: 350*350*155mm.
 4. QTY: 1200pcs/reel, 5reel/carton, total 6000pcs/carton;

GENERAL TOLERANCE		DWG NO.	JYSA0909-001	APPD:	WIND	Scale	1:1
X.±0.45	x.±5'	Title	HDMI D TYPE板上型CH=1.55 双排SMT 外壳四脚插件	CHKD:		UNIT	mm
.X±0.35	.x'±2'			DR:			
.XX±0.25	.xx'±1'	Part NO.	包装图	Date	2016/10/31		
.XXX±0.15	.xxx'±0.5'						
SHEET	2/2			 JYSCONN Shenzhen JYSCONN Electronics Co., LTD.			