

REV.	ECN. NO.	MODIFY. CONTENT	DATE
A		NEW	2011/10/31

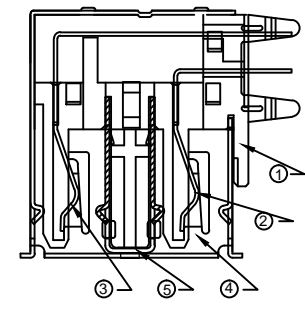
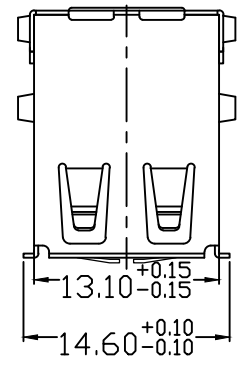
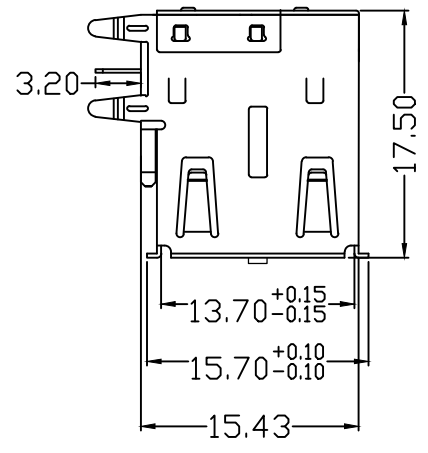

规格说明: Specifications:

电气特性: Electrical:

1. 额定电流: Current Rating  
1.5A/contact terminal
2. 额定电压: Voltage Rating  
30V DC
3. 接触阻抗: Contact Resistance  
30 milliohms MAX
4. 耐电压: Dielectric Withstanding Voltage:  
500 V AC AT Sea Level
5. 绝缘阻抗: Insulation Resistance:  
1000MEGA ohms MIN

物理性能: Mechanical:

1. 插拔力: Connector Mate and Unmate Force  
Mate force: 3.57kgf (MAX)  
Unmate force: 1.02kgf (MIN)
2. 端子保持力: Terminal Retention  
1.0kgf (MIN)

原材料: Material:

1. 塑胶: Housing:  
Hing Temperature Thermoplastics,  
PBT White/Black
2. 端子: Contact: Copper Alloy C2680  
Plated Gold in Mating Area;  
Tin On Solder Talls
3. 外壳: Shell: Copper Alloy SPCC  
Nickel Plating

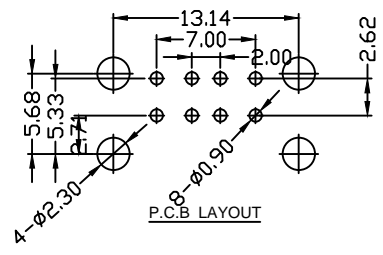
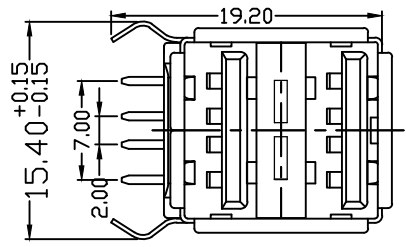

5	SHELL-B	Fe	T=0.30	N 180- 100U*	1
4	SHELL-A	Fe	T=0.30	N 180- 100U*	1
3	TERMINAL-B	BRASS	T=0.25	Sn 100U*+ Au 1U*	4
2	TERMINAL-A	BRASS	T=0.25	Sn 100U*+ Au 1U*	4
1	HOUSING	PBT		WHITE/BLACK	1
NO.	Part Name	MATERIAL	THICK	FINISH	Q'TY

GENERAL TOLERANCE		DWG NO.	JYSA0909-001	APPD:	WIND	Scale	1:1
X. ±0.45	x. °±5°	Title	USB 2.0 A TYPE 双层有后盖 弯脚 (15.4mm)带弹卷边	CHKD:		UNIT	mm
.X±0.35	.x°±2°			DR:			
.XX±0.25	.xx°±1°			Date	2011/10/31		
.XXX±0.15	.xxx°±0.5°	Part NO.	JYS-USB154-054	Shenzhen <b>JYCONN Electronics Co., LTD.</b>			
SHEET	1/1						