

REV.	ECN. NO.	MODIFY. CONTENT	DATE
A		NEW	2017/04/13

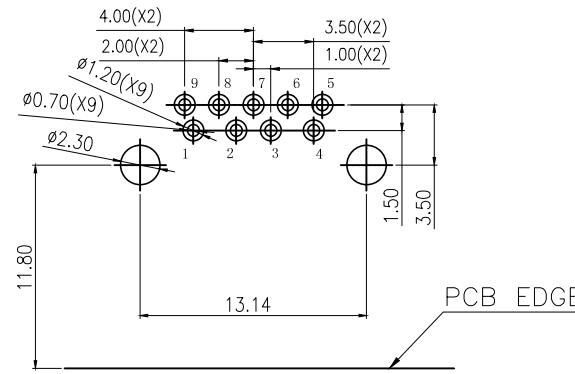

TOLERANCE: ± 0.05 , THICKNESS: 1.6mm
RECOMMENDED PCB LAYOUT
 (TOP VIEW)

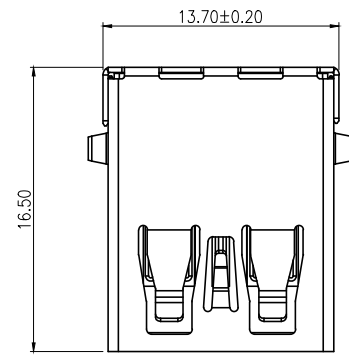
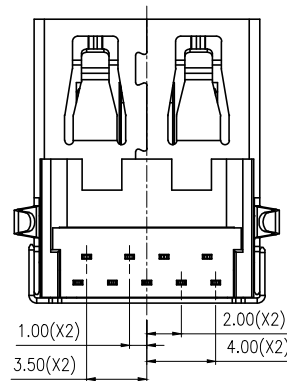
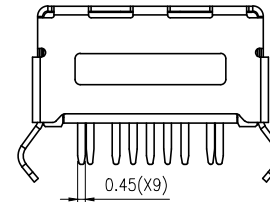
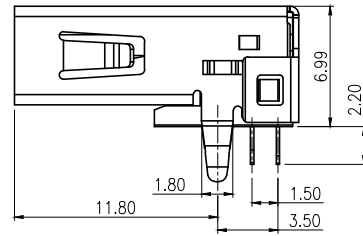
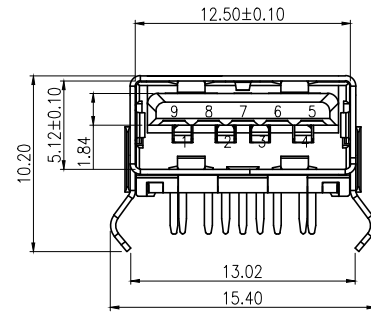

NOTE:

- MATERIAL:
SEE TABLE
- ELECTRICAL CHARACTERISTICS:
 - CONTACT RESISTANCE: 30mΩ Max
 - CONTACT CURRENT RATING: 1.5A
 - DIELECTRIC WITHSTANDING VOLTAGE: 100 V R.M.S.
 - INSULATION RESISTANCE 100 MEGOHMS Min
 - OPERATING TEMPERATURE: -25° C ~ 75° C
- MECHANICAL CHARACTERISTICS:
 - MATING FORCE: 35 N Max
 - UNMATED FORCE: 10 N Min
 - DURABILITY MANDATORY: 1500 CYCLES

PIN No.	SIGNAL NAME	PIN No.	SIGNAL NAME
1	VBUS	6	STDA_SSRX+
2	D-	7	GND_DRAIN
3	D+	8	STDA_SSTX-
4	GND	9	STDA_SSTX+
5	STDA_SSRX-	SHELL	SHIELD

TABLE: (表)

ITEM NO.	PART NAME (零件名称)	QTY (数量)	Material (材质描述)
1	SHELL (外壳)	1	C2880, Nickel 500*Min (黄铜, 镀500*最小)
2	HOUSING (胶芯)	1	PBT+30%GF BLACK, U94V-0 (PBT 黑色 B4HS)
3	2.0CONTACT (2.0端子)	4	G5191-BH, GOLD 1U" (磷铜C2680-BH, 半光亮镀1U")
4	3.0CONTACT (3.0端子)	5	C2680-BH, GOLD 1U" (磷铜C2680-BH, 半光亮镀1U")
5	Cover (后盖)	1	PBT+30%GF BLUE, U94V-0 (PBT 蓝色 B4HS)
2	HOUSING (胶芯)	1	PBT+30%GF BLACK, U94V-0 (PBT 黑色 B4HS)
4	Cover (后盖)	1	PBT+30%GF BLACK, U94V-0 (PBT 黑色 B4HS)

GENERAL TOLERANCE		DWG NO.	JYSA0804-001	APPD:	WIND	Scale	1:1
X. ± 0.45	x. $^{\circ} \pm 5^{\circ}$	Title	USB3.0 AF 90度 DIP 16.50长 H=7.0弯脚 直边	CHKD:		UNIT	mm
.X ± 0.35	.x $^{\circ} \pm 2^{\circ}$			DR:			
.XX ± 0.25	.xx $^{\circ} \pm 1^{\circ}$	Part NO.	JYS-USB700-055	Date	2017/04/13		
.XXX ± 0.15	.xxx $^{\circ} \pm 0.5^{\circ}$			Shenzhen JYSCONN Electronics Co., LTD.			
SHEET	1/1						