

REV.	ECN.NO.	MODIFY.CONTENT	DATE
A		NEW	2022/05/29

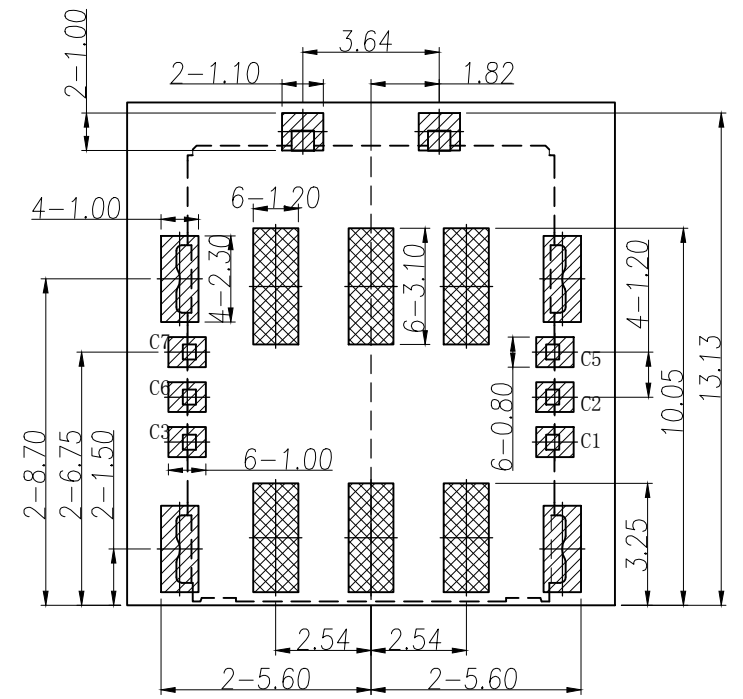
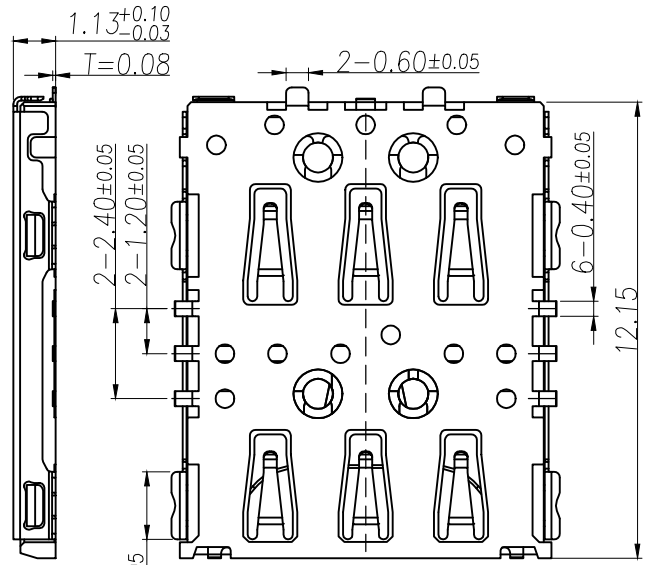
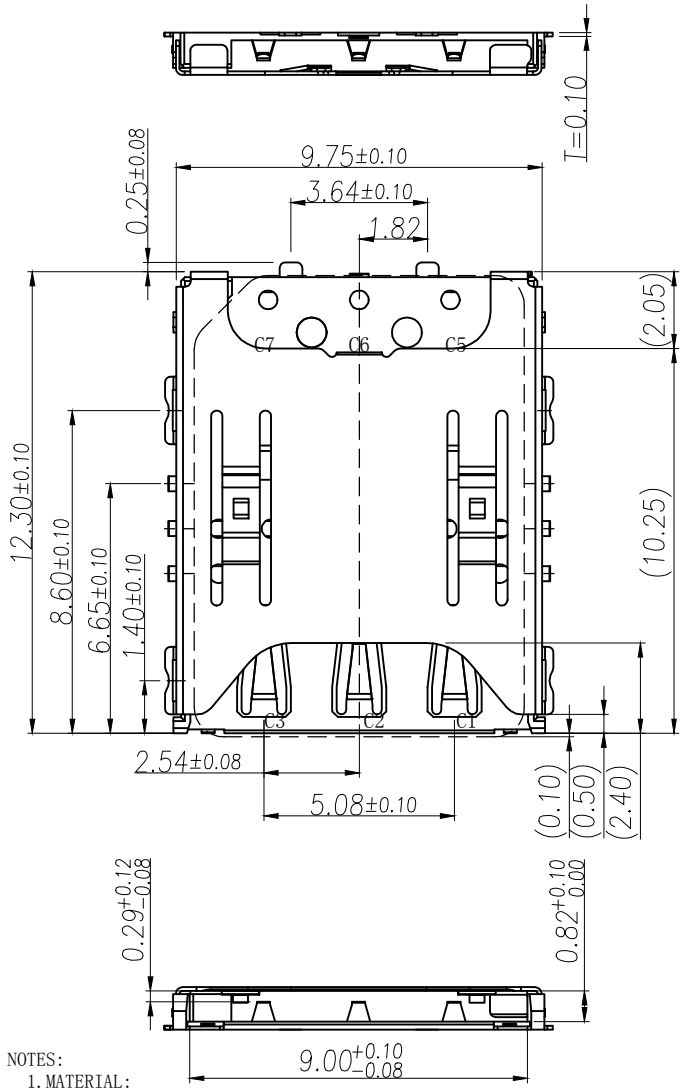

RECOMMENDED PCB LAYOUT
TOLERANCE: ±0.05

- SMT SOLDER AREA
- COPPER RESTRICTED AREA
- 1. TOUCH AREA OF CONTACT
TIPS NO ELECTRICAL FUNCTION
- 2. NO FIRST PCB_LAYOUT
CIRCUITS IN THE AREA

NOTES:

- MATERIAL:**
 HOUSING:High Temperature Thermoplastic
 Terminal:Copper Alloy
 Shell:Stainless Steel
- PLATING:**
 Terminal:30u" Ni UNDERPLATED OVERALL
 G/F PLATED ON CONTACT AREA
 100u" TIN PLATED ON SOLDER AREA
 Shell:50u" Ni UNDERPLATED OVERALL
 G/F PLATED ON CONTACT AREA AND SOLDER AREA
- TECHNICAL SPECIALITY:**
 RATED VOLTAGE:30V AC MAX.
 CURRENT RATING:0.5A MAX.
 INSULATION RESISTANCE:1000MΩ MIN
 CONTACT RESISTANCE:100mΩMAX
 WITHSTANDING VOLTAGE:500V AC FOR 1 MINUTES
 OPERATING TEMPERATURE:-20℃~+85℃ Humidity80%R.HMAX

PIIN/NO	ASSIGNMENT
C1	VCC
C2	RST
C3	CLK
C5	GND
C6	VPP
C7	I/O

GENERAL TOLERANCE		DWG NO.	APPD:		WIND	Scale	1:1
X.±0.45	x.*±5°	Title	1. 13H NANO SIM 6PIN 直插式		CHKD:	UNIT	mm
.X±0.35	.x.*±2°		DR:				
.XX±0.25	.xx.*±1°	Part NO.	JYS-SIM113-215	Date	2022/05/29		
.XXX±0.15	.xxx.*±0.5°			JYSCONN Electronics Co., LTD.			
SHEET	1/2						

REV.	ECN.NO.	MODIFY.CONTENT	DATE
A		NEW	2022/05/29

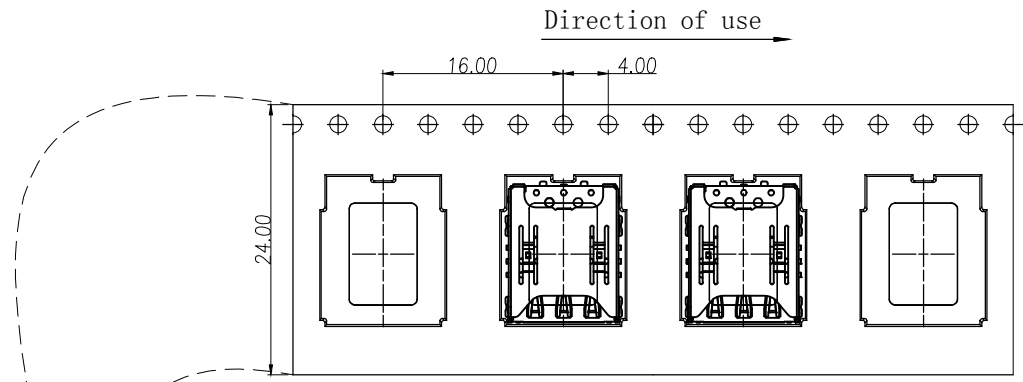

NOTES:

- 1、Packing quantity per plate: 2000PCS/Plate
- 2、Loading and packing method

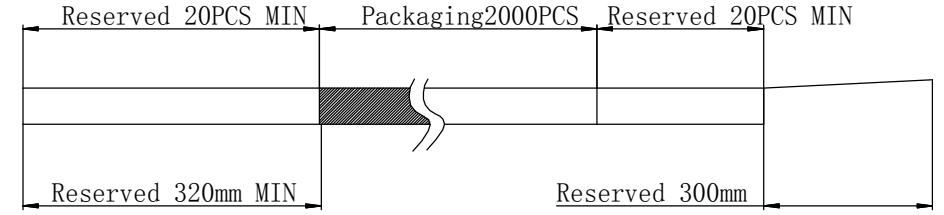

- 3、Total packaging: 20000PCS/Box

OVER TAPE PEELING FORCE: 20gf~120gf

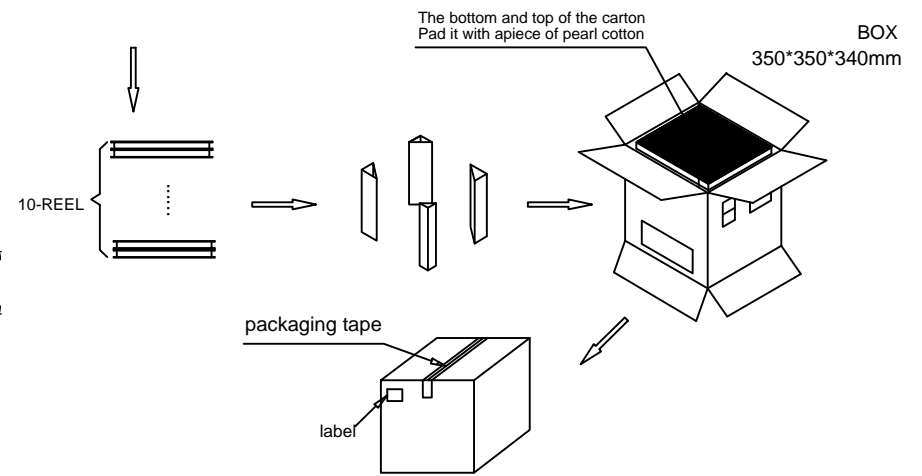
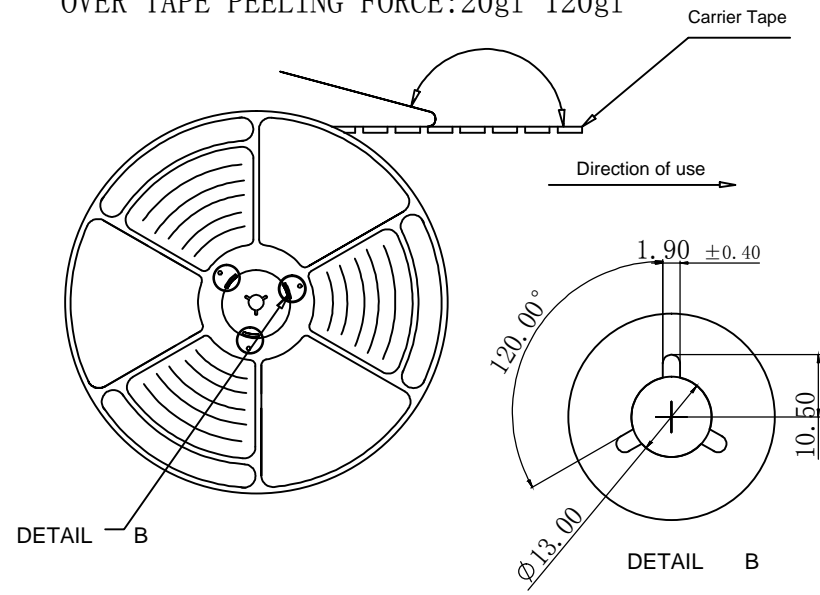

GENERAL TOLERANCE		DWG NO.		APPD:	WIND	Scale	1:1
X.±0.45	x.*±5°	Title	1. 13H NANO SIM 6PIN 直插式 包装图	CHKD:		UNIT	mm
.X±0.35	.x.*±2°			DR:			
.XX±0.25	.xx.*±1°	Part NO.	JYS-SIM113-215	Date	2022/05/29		
.XXX±0.15	.xxx.*±0.5°			Shenzhen JYSCONN Electronics Co., LTD.			
SHEET	2/2						